

# 78200/18200 Series *LINCOLNLOG*<sup>™</sup> Valves Anti-cavitation High Pressure Control Valves

Featuring High Resistance Multiple Stage *LINCOLNLOG* Trim  
Angle Configuration 78200  
Globe Configuration 18200

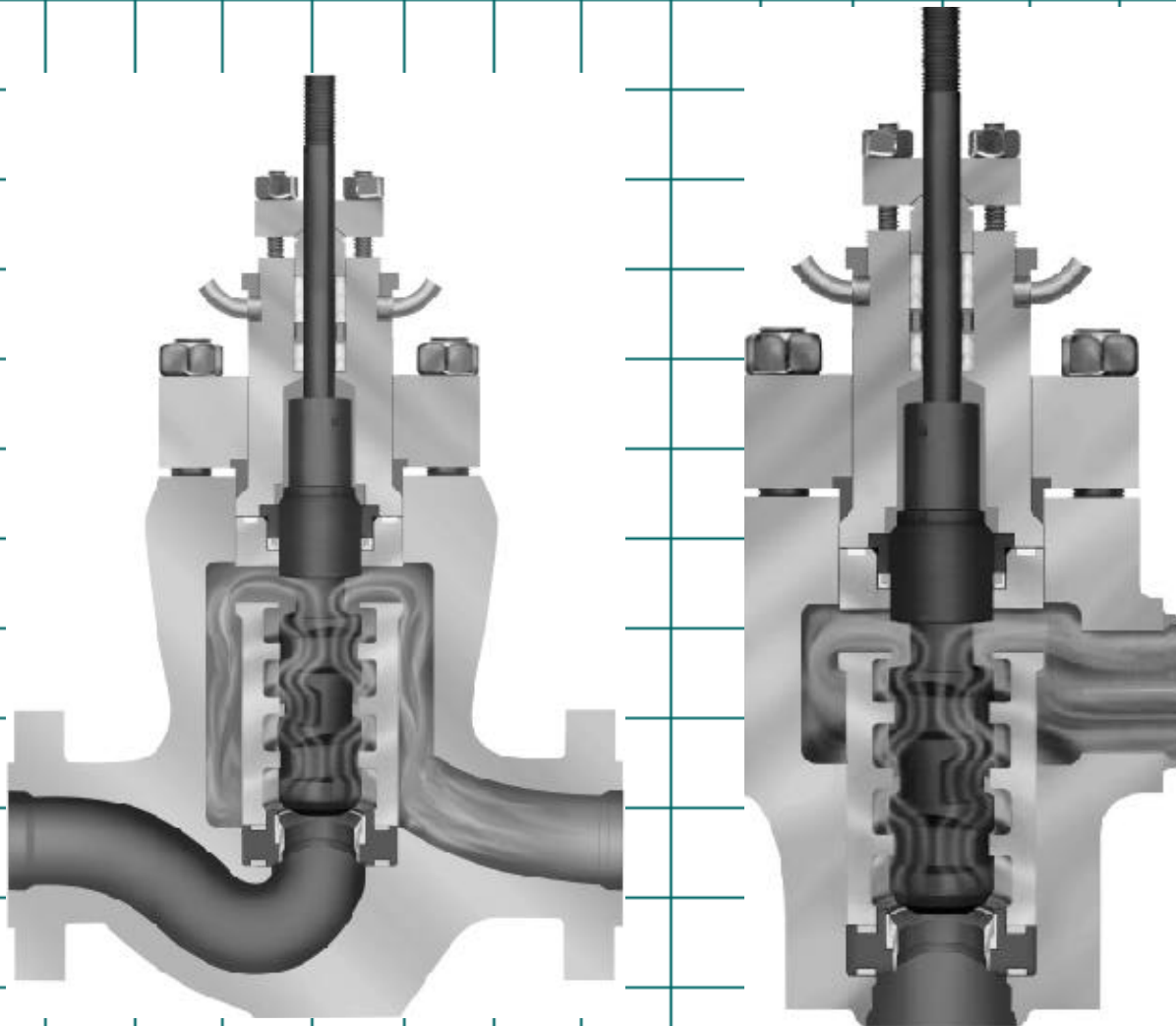

**Masoneilan**  
Valve & Controls 

## Table of Contents

Model Numbering System .....	3
Ratings (ANSI Class) and Connections .....	3
General Data .....	3
Temperature Range/Seat Leakage .....	4
Flow Coefficients .....	4
Trim Details .....	5
Materials .....	6 - 9
Allowable Pressure Drops .....	10 - 11
Dimensions and Weights .....	12 - 16
Sizing Guidelines .....	17
Accessories and Options .....	18

## Foreword

The 78200/18200 Series *LINCOLNLOG™* valves provide smooth and accurate capacity control of high pressure drop liquids without cavitation, erosion, vibration and high noise levels associated with conventional single stage control devices.

Masoneilan's Lincolnlog valve design is based on the principle of high resistance multistep axial flow trim. In an axial flow trim, fluid flow is parallel to the axis of the plug and cage. Pressure reduction occurs along the length of the plug; therefore, no individual stage is ever exposed to the full pressure differential. As a result, trim life is greatly extended

The Lincolnlog trim design offers a unique configuration with a series of equal capacity stages, to control erosion, followed with last stage expansion to reduce the potential for cavitation. This valve staging is designed to limit pressure drop per stage, controlling fluid velocity and greatly extending trim life in severe services.

Because of the relatively large flow passages and shearing action provided by the multistep plug and cage designs, these valves are particularly well-suited for applications involving fluids with entrained particles, a potentially serious problem for other valve designs which are subject to clogged flow passages. Good throttling resolution is provided on even small  $C_v$ s.

Simple trim construction eliminates maintenance problems and allows for easy custom design to meet specific applications.

Optional trim staging configurations can be provided for compressible, two-phase, and flashing fluid conditions. A higher number of stages can be provided for higher P requirements.

### Tight Shutoff

Protection against seat erosion is ensured by provision of ANSI FCI 70.2 Class V seat shutoff when standard metal seats are furnished. Class VI seat shutoff is available when optional soft seats are supplied.

### High Allowable Pressure Drops

With balanced trim for valve sizes 1½" through 8", a wide range of allowable pressure drops is available with conventional spring diaphragm or piston actuators. Trim and body materials are available for NACE and corrosive applications.

The unbalanced trim design is suitable for slurry or high temperature services. Valves are provided with large diameter stems and appropriate actuators, allowing high pressure drops in unbalanced construction.

### Variation of Body Configurations

Standard angle or globe body styles with various end connection configurations are offered to accommodate a variety of piping requirements. Oversized or reduced end connections are available and face-to-face dimensions may be matched to existing installations.

Lincolnlog valve bodies are available in cast globe or forged globe and angle designs. A variety of carbon, low alloy, and high alloy steels are available.

### Typical Applications

#### Power Industry

- Boiler feed pump recirculation
- Desuperheater spray nozzle control
- Labyrinth pump seal pressure control
- Feedwater start-up regulators
- Economizer bypass

#### Oilfield

- Water injection pump recirculation
- Produced/waste water injection well control
- H. P. separator letdown

#### Refinery

- H<sub>2</sub>S contactor letdown (DEA, MEA, Glycol)
- Charge pump recirculation
- Reactor cold separator letdown

## Model Numbering System

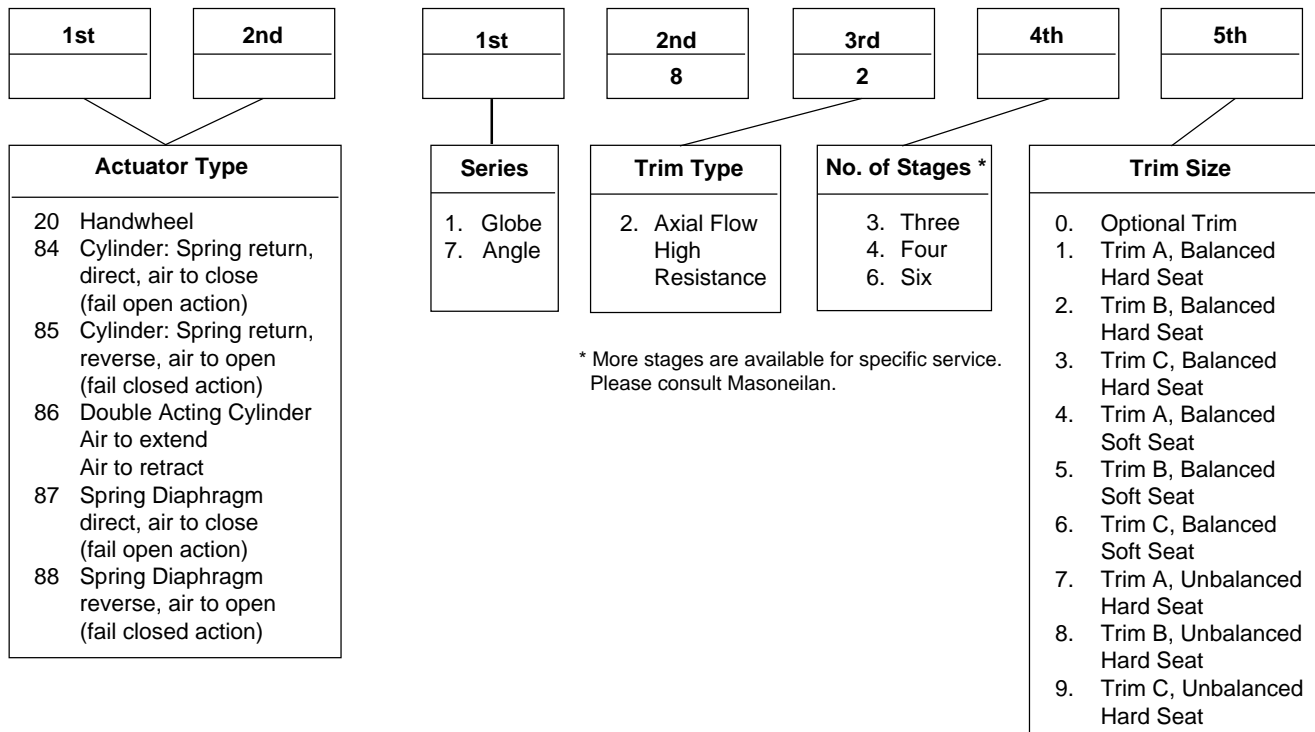

## Ratings (ANSI Class) and Connections

Size (in.)	ANSI			
	600	900	1500	2500
1 and 1½	□ ● ■ ▼	□ ● ■ ▼	□ ● ■ ▼	□ ● ■ ▼
2	□ ● ■ ▼	□ ● ■ ▼	□ ● ■ ▼	□ ● ■ ▼
3	■ ▼	■ ▼	■ ▼	■ ▼
4	■ ▼	■ ▼	■ ▼	■ ▼
6	■ ▼	■ ▼	■ ▼	■ ▼
8	■ ▼	■ ▼	■ ▼	■ ▼

Threaded  
 Socket Weld\*  
 Butt Weld\*  
 RF Flange  
 RTJ Flange

\* Pipe nipples and reducers can be provided.

Note: Other flange ratings and end connections are available.

## General Data

### • Body

type: 1" through 8" forged angle  
1" through 6" forged globe  
2" through 8" cast globe (3- and 4-stage)

flow direction: flow to open (flow to close optional)

C<sub>v</sub> ratio: see flow coefficient table on page 4

### • Bonnet

type: stud bolted

### • Trim

type: multiple step axial flow  
characteristic: modified linear

### • Actuator

type: conventional multi-spring diaphragm, spring piston, throttling piston, manual handwheel

For other types of actuators, please consult Masoneilan.

## Temperature Range/Seat Leakage

Size (in.)	Design	Temperature Range		Seat Leakage ANSI FCI 70.2 Class
		Minimum	Maximum	
1	Unbalanced Metal Seat	-20°F	+500°F	V
1½ - 8	Standard Balanced Metal Seat	-20°F	+450°F	V
	Optional Unbalanced Metal Seat	-20°F	+500°F	
2 - 8	Optional Soft Seat	-20°F	+450°F	VI

Note: Other designs for higher and lower temperatures are available. Please contact Masoneilan

## Flow Coefficients: Rated $C_v$ , Critical Flow Factor - $F_L$ and Minimum Controllable $C_v$

Size (in.)	Orifice Diameter (in.)	Travel (in.)	Standard Capacity Trim																
			3-Stage				4-Stage						6-Stage						
			C		Min. Cont.	A		B		C		Min. Cont.	A		B		C		Min. Cont.
			$C_v$	$F_L$		$C_v$	$F_L$	$C_v$	$F_L$	$C_v$	$F_L$		$C_v$	$F_L$	$C_v$	$F_L$	$C_v$		
1	.70	.25	2.0	.98	.05	1.0	.996	1.4	.994	1.7	.991	.04	.80	.998	1.0	.997	1.4	.994	.03
1½	1.00	.25	3.8	.98	.10	1.9	.996	2.5	.994	3.2	.991	.08	1.4	.998	1.8	.997	2.5	.994	.05
2	1.50	.38	9.0	.98	.15	4.5	.996	6.0	.994	7.5	.991	.12	3.5	.998	4.5	.997	6.0	.994	.08
3	2.25	.62	20.0	.98	.25	10.0	.996	13.0	.994	16.5	.991	.20	7.5	.998	9.5	.997	13.0	.994	.13
4	2.88	.75	34.0	.98	.43	16.5	.996	22.0	.994	28.0	.991	.35	12.0	.998	16.0	.997	22.0	.994	.22
6	4.12	1.00	65.0	.98	.56	34.0	.996	45.0	.994	56.0	.991	.46	25.0	.998	35.0	.997	45.0	.994	.30
8	5.38	1.25	135.0	.98	1.0	70.0	.996	90.0	.994	115.0	.991	.80	50.0	.998	65.0	.997	91.0	.994	.65

Note:  $F_L$  is only a function of trim selection and is constant over the full valve travel.

% Max Opening	5	10	20	30	40	50	60	70	80	90	100
% Max $C_v$	①	①	3	15	27	39	52	64	76	88	100

① = Clearance flow only.

## Trim Details

### Characteristics

The Lincolnlog trim has a basic linear control characteristic.

The trim is designed for "clearance" flow capacity over 15% of the initial valve travel.

The multistage "clearance" flow design has been introduced intentionally to avoid high pressure drops in the seating area during throttling at low capacity. This feature extends the shutoff capability significantly and has a positive influence on the throttling control capability at low capacity of this design.

The 15 to 100% of the plug travel provides smooth, accurate and continuous capacity control.

Controllability extends from maximum  $C_v$  value to minimum controllable  $C_v$  and provides a controllable turndown of 50:1 for all except the smallest sizes.

### Lincolnlog $C_v$ vs. Travel

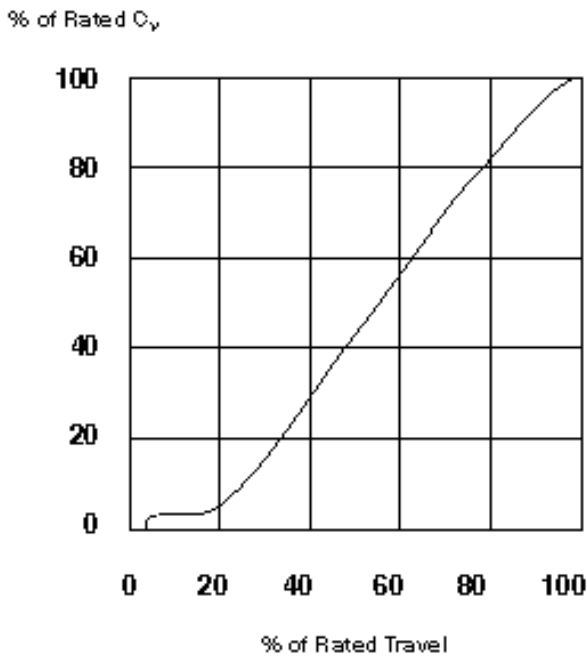

### Lincolnlog Trim Overlap Seat Protection and $C_v$ vs. Travel

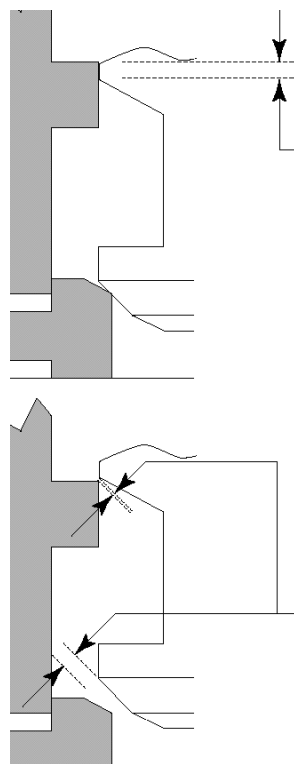

**0 - 15% of Plug Travel**  
Trim overlap with the valve in the closed or low lift positions.

**15 - 100% of Plug Travel**  
There is much greater flow area through the valve seat than plug notches. As the result, pressure drop and velocities across the critical seating surfaces are controlled eliminating seat damage.

### Soft Seat Design (Available in 2" - 8" Sizes)

The "sliding collar" soft seat is a patented Masoneilan design feature. In combination with the 15% trim overlap design in flow to open direction, it will provide long term shutoff capability and minimal maintenance.

Fluid pressure pushes the collar up to protect the elastomer seat when the valve is throttling. The "reservoir" of filled PTFE material compensates for wear of the seat as well.

### Soft Seat Option

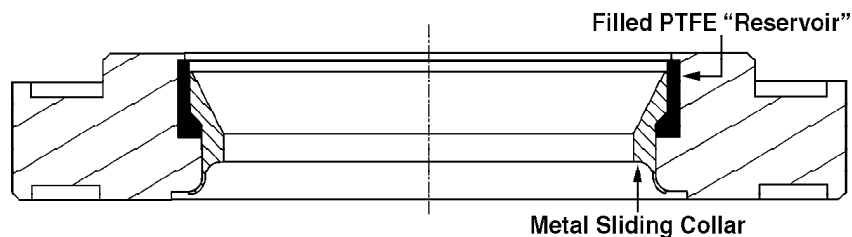

## Valve Sizes 1" and 1 1/2"

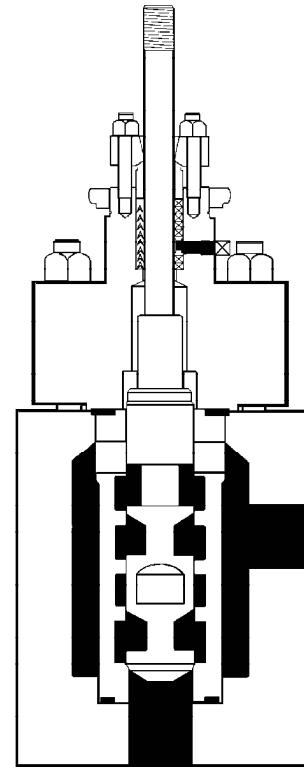

1" Unbalanced Plug with  
Integral Seat Design

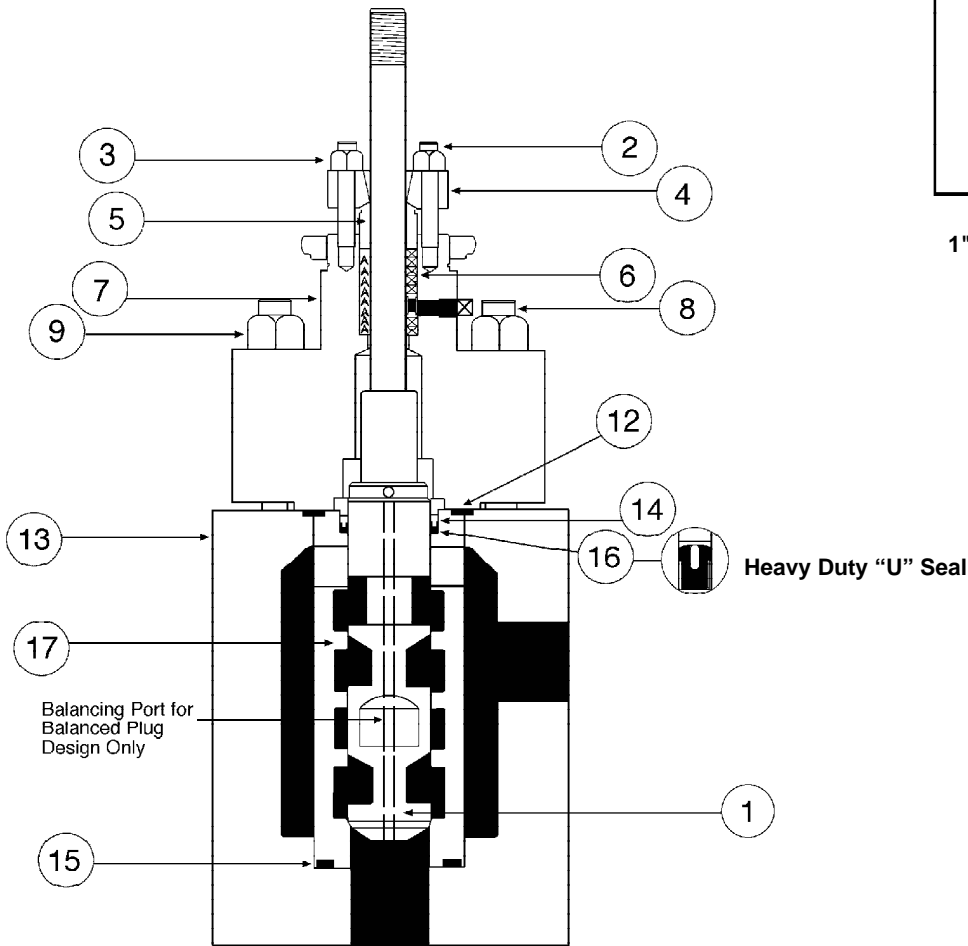

1 1/2" Balanced Plug Design  
with Integral Seat Design

## Materials - Valve Sizes 1" and 1½"

Temperature: -20°F to +450°F (500°F for Unbalanced)		
Ref. No.	Description	Standard Materials
1	Plug with Integral Stem	410 St. St. ASTM 479
2	Packing Flange Stud	Alloy Steel ASTM A193 Gr B7
3	Packing Flange Nut	304 St. St. ASTM A194 Gr 8
4	Packing Flange	Carbon Steel
5	Packing Follower	303 St. St. ASTM A582
6	Packing Set	TFE V-Ring (Crane 285K and Flexible Graphite Optional)
7	Bonnet	Carbon Steel ASTM A105
8	Body Stud	Alloy Steel ASTM A193 Gr B7
9	Body Stud Nut	Alloy Steel ASTM A194 Gr 2H
12	Bonnet Gasket	304 St. St. with Flexible Graphite Filler
13	Body	Carbon Steel ASTM A105
14	Seal Retainer	316 St. St. ①
15	Seat Ring Gasket	304 St. St. with Flexible Graphite Filler
16	Balance Seal	Carbon-Graphite Filled PTFE ①
17	Liner with Integral Seat	17-4 PH Condition H900

## Materials for NACE or Sour Gas Service

Temperature: -20°F to +450°F (500°F for Unbalanced)		
Ref. No.	Description	Optional Materials
1	Plug with Integral Stem	17-4 PH Condition H-1150M
2	Packing Flange Stud	Alloy Steel ASTM A193 Gr B7
3	Packing Flange Nut	304 St. St. ASTM A194 Gr 8
4	Packing Flange	Carbon Steel
5	Packing Follower	303 St. St. ASTM A582
6	Packing Set	TFE V-Ring (Crane 285K and Flexible Graphite Optional)
7	Bonnet	Carbon Steel ASTM A105
8	Body Stud	Alloy Steel ASTM A193 Gr B7
9	Body Stud Nut	Alloy Steel ASTM A194 Gr 2H
12	Bonnet Gasket	304 St. St. with Flexible Graphite Filler
13	Body	Carbon Steel ASTM A105
14	Seal Retainer	316 St. St. ①
15	Seat Ring Gasket	304 St. St. with Flexible Graphite Filler
16	Balance Seal	Carbon-Graphite Filled PTFE ①
17	Liner with Integral Seat	Nitronic 50 ASTM A479 XM-19

Note: Alternate materials available depending on application requirements.

① Seal and retainer not required on 1" valves.



Valve Sizes 2", 3", 4", 6", and 8"

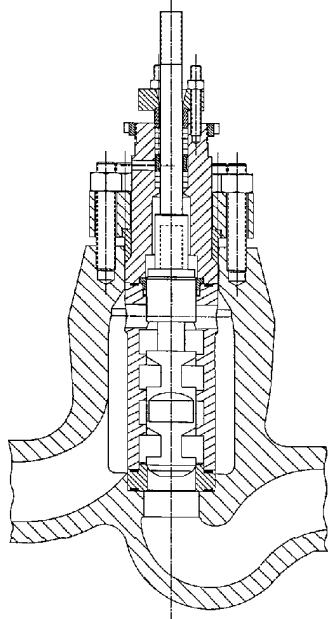

**Cast Globe Body**  
Available in 2", 3", 4", 6", and 8"  
4-Stage

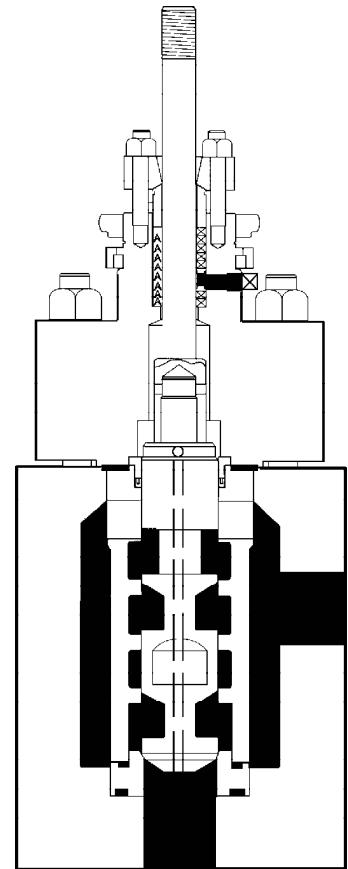

**Forged Angle Body**  
2" Design

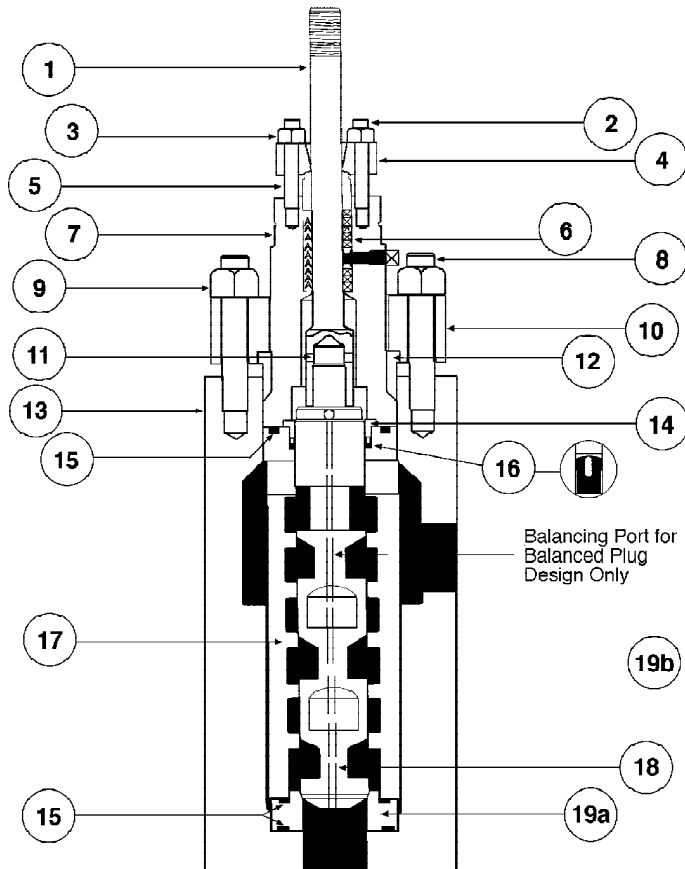

**Forged Angle Body**  
3" through 8"

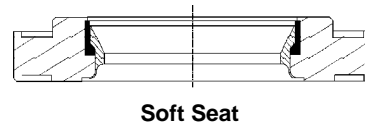

**Soft Seat**



**Materials - Valve Sizes 2", 3", 4", 6" and 8"**

<b>Temperature: -20°F to +450°F (500°F for Unbalanced Hard Seat)</b>		
<b>Ref. No.</b>	<b>Description</b>	<b>Standard Materials</b>
1	Stem	17-4 PH Condition H-1150M
2	Packing Flange Stud	Alloy Steel ASTM A193 Gr B7
3	Packing Flange Nut	304 St. St. ASTM A194 Gr 8
4	Packing Flange	Carbon Steel
5	Packing Follower	303 St. St. ASTM A582
6	Packing Set	TFE V-Ring (Crane 285K or Flexible Graphite Optional)
7	Bonnet	Carbon Steel ASTM A105 Forged
8	Body Stud	Alloy Steel ASTM A193 Gr B7
9	Body Stud Nut	Alloy Steel ASTM A194 Gr 2H
10	Bonnet Flange	Carbon Steel ASTM A516 Gr 70
11	Plug Pin	300 Series St. St.
12	Metal Seal	17-4 PH Condition H-1150M (2" size, 304 St. St. with Flexible Graphite Filler)
13	Body	Carbon Steel ASTM A105 Forged (A216 WCB Cast)
14	Seal Retainer	316 St. St.
15	Bonnet Gasket	304 St. St. with Flexible Graphite Filler
	Seat Ring Gasket	304 St. St. with Flexible Graphite Filler
16	Balance Seal	Carbon-Graphite Filled PTFE
17	Liner/Cage	17-4 PH Condition H900
18	Plug	410 St. St. ASTM A479
19a	Seat Ring	316 St. St. with Hardface
19b	Seat Ring (Soft Seat)	17-4 St. St. Condition H-1150M with Filled PTFE Seal

**Materials for NACE or Sour Gas Service**

<b>Temperature: -20°F to +450°F (500°F for Unbalanced Hard Seat)</b>		
<b>Ref. No.</b>	<b>Description</b>	<b>Optional Materials</b>
1	Stem	17-4 PH Condition H-1150M
2	Packing Flange Stud	Alloy Steel ASTM A193 Gr B7
3	Packing Flange Nut	304 St. St. ASTM A194 Gr 8
4	Packing Flange	Carbon Steel
5	Packing Follower	303 St. St. ASTM A582
6	Packing Set	TFE V-Ring (Crane 285K or Flexible Graphite Optional)
7	Bonnet	Carbon Steel ASTM A105 Forged
8	Body Stud	Alloy Steel ASTM A193 Gr B7
9	Body Stud Nut	Alloy Steel ASTM A194 Gr 2H
10	Bonnet Flange	Carbon Steel ASTM A516 Gr 70
11	Plug Pin	300 Series St. St.
12	Metal Seal	17-4 PH Condition H-1150M (2" size, 304 St. St. with Flexible Graphite Filler)
13	Body	Carbon Steel ASTM A105 Forged (A216 WCB Cast)
14	Seal Retainer	316 St. St.
15	Bonnet Gasket	304 St. St. with Flexible Graphite Filler
	Seat Ring Gasket	304 St. St. with Flexible Graphite Filler
16	Balance Seal	Carbon-Graphite Filled PTFE
17	Liner/Cage	Nitronic 50 ASTM A479 XM-19
18	Plug	17-4 PH Condition H-1150M
19a	Seat Ring	316 St. St. with Hardface
19b	Seat Ring (Soft Seat)	17-4 St. St. Condition H-1150M with Filled PTFE Seal

Note: Alternate materials available depending on application requirements.

## Allowable Pressure Drops (psi)

### Models 87 and 88 Spring Diaphragm Actuators

Temperature: -20°F to +450°F (500°F)  
 Flow Direction: Flow to Open  
 Trim: Unbalanced (1") Balanced (1½" - 6") ①  
 Metal Seat: Seat Leakage per ANSI FCI 70.2 Class V (1" - 6")  
 Soft Seat: Seat Leakage per ANSI FCI 70.2 Class VI (2" - 6")

Valve Size (in.)	Travel (in.)	Actuator Size	87 Multi-Spring Actuator Air to Close			88 Multi-Spring Actuator Air to Open		
			Air Supply (psig)	Spring Range (psig)	P Shutoff (psi)	Air Supply (psig)	Spring Range (psig)	P Shutoff (psi)
1	.25	6	40 60	6 - 14 6 - 14	1600 4750	50	38 - 45	3325
		10	40 60	6 - 14 6 - 14	4375 6250	50	38 - 45	6250
1½	.25	6	40 60	6 - 14 6 - 14	1075 6250	50	38 - 45	4950
		10	40	6 - 14	6250	50	38 - 45	6250
2	.38	10	60	6 - 17	4800	50	34 - 45	2750
		16	40 60	6 - 17 6 - 17	3375 6250	50	34 - 45	6250
3	.62	16	60	6 - 16	4750	50	35 - 45	2925
		23	40 60	6 - 16 6 - 16	2835 6250	50	35 - 45	6025
4	.75	16	60	6 - 18	3275	50	-	-
		23	40 60	6 - 18 6 - 18	1100 6250	50	33 - 45	4425
6	1.00	23	60	6 - 18	3725	50	33 - 45	1550

① Consult factory for unbalanced trim pressure drops or high temperature applications over 450°F.

Spring Diaphragm Positioner Selection: 1" - 1½" - 2" Moore 750P, 3" - 4" - 6" Masoneilan 4700P, 4700E, or 8012.

## Allowable Pressure Drops (psi)

### Models 84 and 85 Spring Cylinder Actuators

Temperature: -20°F to +450°F (500°F)  
 Flow Direction: Flow to Open  
 Trim: Balanced (6" - 8") ①  
 Metal Seat: Seat Leakage per ANSI FCI 70.2 Class V (6" - 8")  
 Soft Seat: Seat Leakage per ANSI FCI 70.2 Class VI (6" - 8")

Valve Size (in.)	Travel (in.)	Actuator Size	84 Spring Piston Actuators Air to Close			85 Spring Piston Actuators Air to Open			
			Air Supply (psig)	Spring Range (psig)	P Shutoff (psi)	Air Supply Min/Max (psig)	Spring Range (psig)	P Shutoff (psi)	Manual Over Ride
6	1.00	154	60 80 100	10 - 12 10 - 12 10 - 12	1200 4450 6250	40 / 80	25 - 29	3225	Hydraulic Jack
		314	40 60	10 - 12 10 - 12	2550 6250	40 / 60	25 - 29	6250	Hydraulic Jack
8	1.25	154	80 100	10 - 12 10 - 12	3025 6250	40 / 60	25 - 30	3850	Hydraulic Jack
		314	60 80	10 - 12 10 - 12	6250 6250	40 / 60	25 - 30	6250	Hydraulic Jack

① Consult factory for unbalanced trim pressure drops or high temperature applications over 450°F.

② For air to open action, the actuator must have double acting positioner or use 4-way solenoid for Class V or Class VI shutoff. Without air on the spring side of the cylinder, the valve shutoff rating is Class III.

Spring Cylinder Positioner Selection: 6" - 8" Moore 750P/750E or Bailey AV1/AV2.

## Allowable Pressure Drops (psi)

### Model 20 Manual Actuators

Valve Size (in.)	Travel (in.)	Model 20 Manual Actuators		
		Yoke Size	Actuator (in.)	Allowable Pressure Drop (psi)
1	.25	B	12	5300
1½	.25	B	12	6250
2	.38	C	18	6250
3	.62	D-12	18	6250
4	.75	D-12	18	6250
6	1.00	D-16	18	6250
8	1.25	C/F	C/F	C/F

## Dimensions (in.) and Weights (lbs)

### Body Subassembly Forged Configuration (78200 Series)

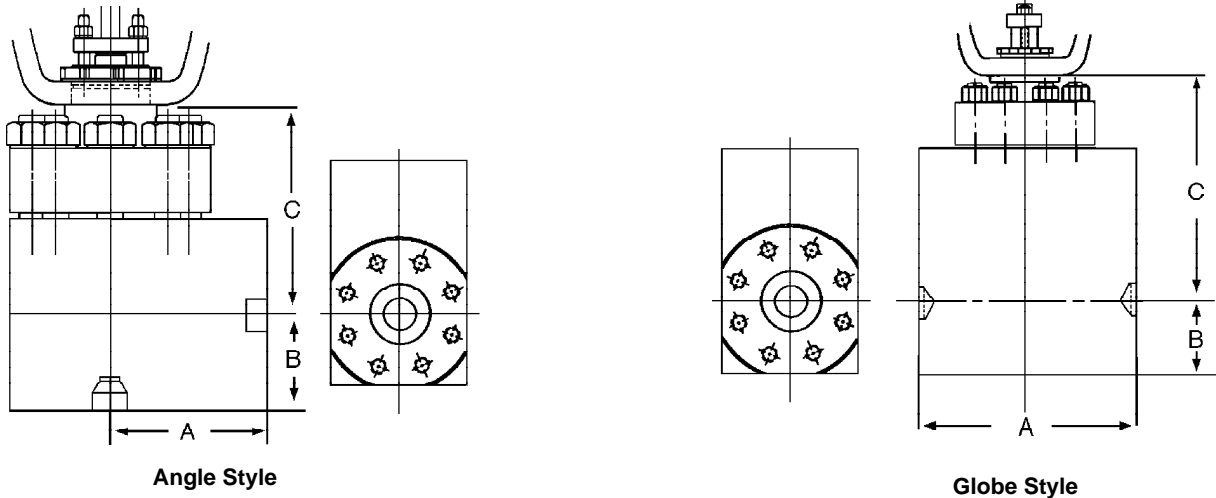

Size (in.)	ANSI Class	End Conn.	78200 4- and 6-Stage Forged Angle					18200 4- and 6-Stage Forged Globe			
			Stage	A ①	B	C	Valve (lbs)	Stage	A	B	C
1	600 - 2500	Flg	4	4.50	2.75	6.00	85	4	① For Dimensions and Weights Consult Factory		
			6		3.75		95				
		SW	4	2.88	2.50		56				
			6		3.88		66				
1 1/2	600 - 2500	Flg	4	5.50	3.25	6.25	110	4			
			6		4.00		125				
		SW	4	2.88	2.75		60				
			6		4.12		88				
2	600 - 1500	Flg	4	3.88	6.00	8.81	230	4			
			6		7.00		248				
		SW	4	4.00	6.00		188				
			6		6.00		218				
	2500	Flg	4	3.88	6.00	8.81	230	4			
			6		7.00		248				
		SW	4	4.00	6.00		188				
			6		6.00		218				
3	600 - 1500	Flg & BW	4	4.75	7.75	9.00	290	4			
			6		11.00		375				
	2500	Flg & BW	4	5.25	7.75		9.50		380	4	
			6		11.00				480		
4	600 - 1500	Flg & BW	4	5.50	8.75	11.50		515	4		
			6		12.75			650			
	2500	Flg & BW	4	6.25	8.75		11.50	665		4	
			6		12.75			840			
6	600 - 1500	Flg & BW	4	7.25	11.88	13.00		1250	4		
			6		17.38			1575			
	2500	Flg & BW	4	10.00	11.88		13.75	1845		4	
			6		17.38			2325			
8	600 - 1500	Flg & BW	4	C/F	C/F	C/F		C/F	4		
			6		C/F			C/F			

① Butt weld and socket weld valves can be provided with welding nipples/reducers to fit projected line size(s) and schedule(s).

## Dimensions (in.) and Weights (lbs)

### Body Subassembly Cast Configuration (18200 Series)

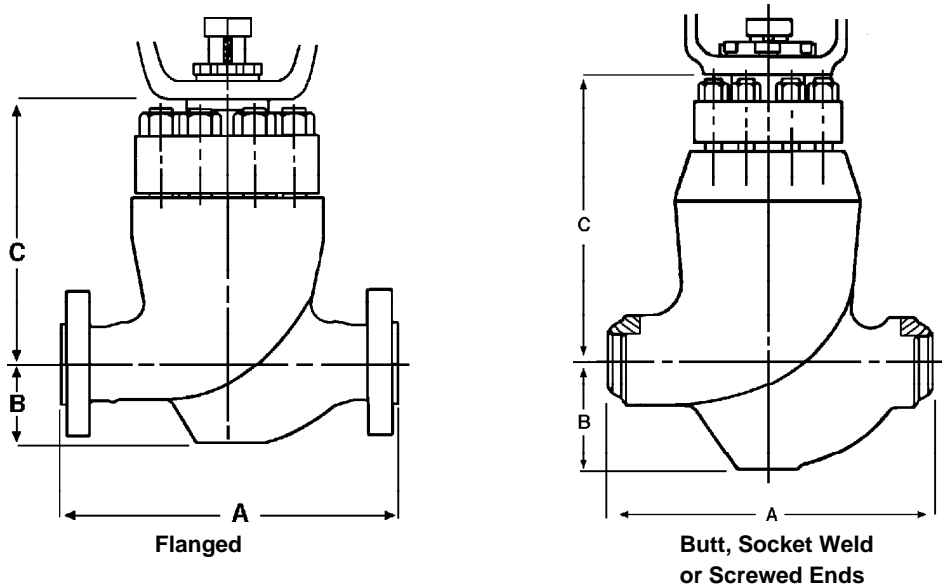

18200 3- and 4-Stage Cast Globe							
Valve Size (in.)	ANSI Class	End Conn.	Stage	A ①	B	C	Weight (lbs)
2	600	RF	3 / 4	14.75	3.60	11.50	150
		RJ		14.88	3.60	11.50	150
		SW / BW		14.75	3.60	11.50	120
	900/ 1500	RF	3 / 4	14.75	3.60	11.50	175
		RJ		14.88	3.60	11.50	175
		SW / BW		14.75	3.60	11.50	130
3	600	RF	3 / 4	17.38	5.25	16	250
		RJ		17.50	5.25	16	250
		BW		17.38	5.25	16	200
	900	RF	3 / 4	17.38	5.25	16	325
		RJ		17.50	5.25	16	325
		SW / BW		17.38	5.25	16	250
	1500	RF	3 / 4	18.12	5.25	16	350
		RJ		18.25	5.25	16	350
		BW		18.12	5.25	16	250
4	600	RF	3 / 4	20.12	7.20	19	450
		RJ		20.25	7.20	19	450
		BW		20.12	7.20	19	390
	900	RF	3 / 4	20.12	7.20	19	550
		RJ		20.25	7.20	19	550
		BW		20.12	7.20	19	460
	1500	RF	3 / 4	20.88	7.20	19	590
		RJ		21.00	7.20	19	590
		BW		20.88	7.20	19	460

① Butt weld and socket weld valves can be provided with welding nipples/reducers to fit projected line size(s) and schedule(s).

## Dimensions (in.) and Weights (lbs)

### Model 87/88 Spring Diaphragm Actuator

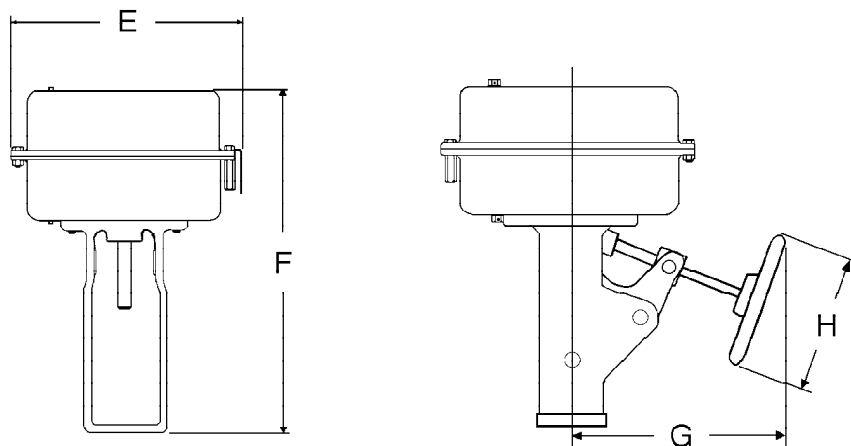

Shown with optional handwheel

### Model 87/88 Spring Diaphragm Actuator Dimensions (in.)

Actuator Size	E	F	G	H
6	11.50	15.54	10.00	9.00
10	14.50	19.58	10.90	12.00
16	18.75	28.22	13.00	18.00
23	21.63	30.71	15.00	18.00

### Weights (lbs)

Actuator Size	Standard	w/Handwheel
6	45	60
10	85	105
16	195	245
23	260	320

## Dimensions (in.) and Weights (lbs)

### Model 84, 85, 86 Cylinder Actuators

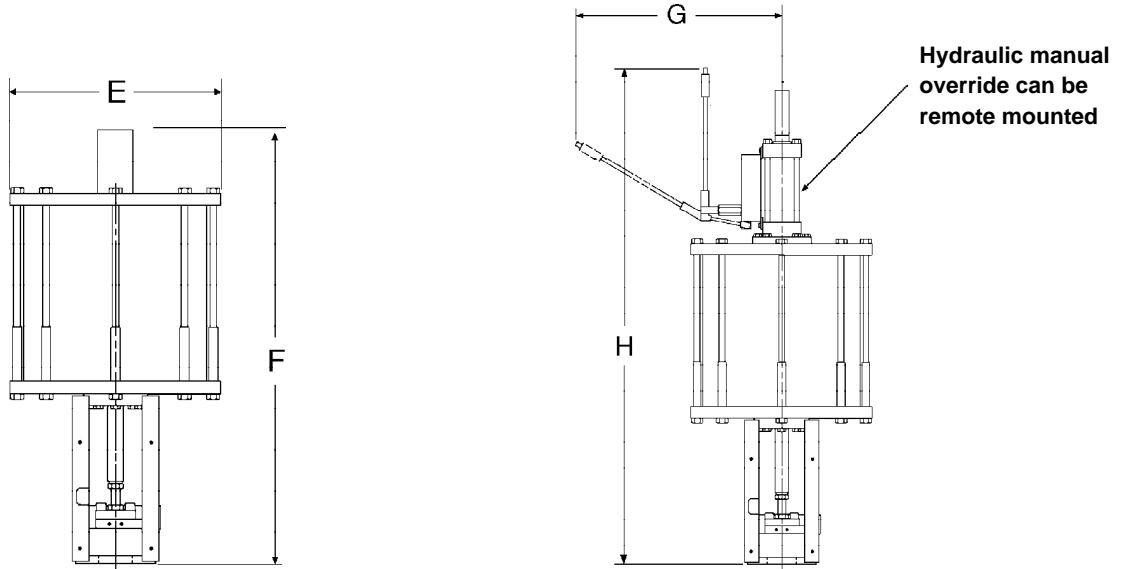

Shown with optional hydraulic manual override  
For 154 sq. in. and 314 sq. in. actuator only

### Model 84, 85 and 86 Cylinder - Direct, Reverse and Double Acting Dimensions (in.)

Actuator Size	E	F	G	H
154 sq. in.	18.1	47.8	26.7	60.5
314 sq. in.	23.9	49.8	27.0	62.5

Note: Actuator removal clearance = 6 inches

### Weights (lbs)

Actuator Size	Base Weight	Small Spring	Medium Spring	Large Spring	Manual Override
154 sq. in.	266	60	-	82	100
314 sq. in.	709	60	84	142	100
Nominal Spring Range					
154 sq. in.	-	10 - 20	-	15 - 30	-
314 sq. in.	-	5 - 10	7.5 - 15	12.5 - 25	-



## Model 20 Manual Handwheel

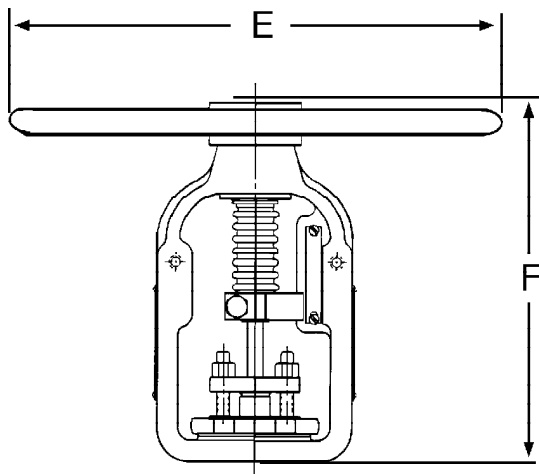

**B and C Yoke**

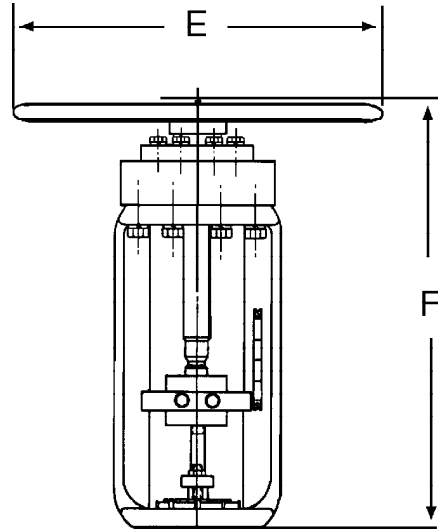

**D Yoke**

### Model 20 Manual Actuator Dimensions (in.)

Valve Size (in.)	Yoke Size	E	F
1	B	12	9.0
1½	B	12	9.0
2	C	18	11.2
3	D-12	18	14.0
4	D-12	18	14.0
6	D-16	18	20.5
8	C/F	C/F	C/F

### Weights (lbs)

Handwheel with Standard Yoke	
<b>B</b>	15
<b>C</b>	32
<b>D-12</b>	50
<b>D-16</b>	80

## LINCOLNLOG™ Valve Sizing Guidelines

Lincolnlog multistep control valves can be sized using standard ISA equations, the sizing procedures from Masoneilan Sizing Handbook, or the computer sizing program furnished by Masoneilan.

Noise calculations are best performed by using the computerized program. The serial stage configuration of the Lincolnlog design reduces valve trim noise significantly. The actual valve noise can be approximated by calculating the last stage noise, using the standard noise calculation procedures. The  $\Delta P$  of the last stage for approximate noise calculating can be derived from the table below.

Selection of the correct trim can be made by determining the  $\Delta P$ /stage from the table below. It is good practice to limit the  $\Delta P$ /stage

to 800 psi for continuous duty cycle and to 1000 psi for intermittent duty. The resulting recommended  $\Delta P$  throttling is shown in the same table.

For flashing flow conditions, the expansion ratio of the fluid shall approximate the staging ratio of the selected trim. Nonstandard staging ratios for compressible, two-phase or flashing conditions can be provided. Please consult factory.

For proper sizing of two-phase and flashing fluid, the inlet and outlet density of the fluid needs to be determined.

**Lincolnlog Pressure Drop Distribution and Recommended Maximum Pressure Drop**

Trim Type	No. of Stages	Staging Ratio	$\Delta P$ Fraction per Stage	Continuous Operation	Intermittent Operation
<b>C</b>	3	1-1-2	.44 Stage 1 to 2 .11 Stage 3	1800	2250
<b>C</b>	4	1-1-1-2	.31 Stage 1 to 3 .08 Stage 4	2600	3250
<b>B</b>	4	1-1-2-3	.42 Stage 1 and 2 .11 Stage 3 .05 Stage 4	1890	2360
<b>A</b>	4	1-1-2-4	.43 Stage 1 and 2 .11 Stage 3 .03 Stage 4	1850	2325
<b>C</b>	6	1-1-1-1-1-2	.19 Stage 1 to 5 .05 Stage 6	4225	5260
<b>B</b>	6	1-1-1-1-2-3	.23 Stage 1 to 4 .06 Stage 5 .025 Stage 6	3500	4375
<b>A</b>	6	1-1-1-1-2-4	.23 Stage 1 to 4 .06 Stage 5 .014 Stage 6	3450	4300

## Accessories and Options

### Accessories

87/88 Actuators  
(See Specification Data CR8788)  
84/85/86 Cylinders  
(See Instruction ER8485)

4700P/4700E Series Positioner  
(See Instruction ES2004 and Supplement to ES2004)  
Instrument Signals 3-15 and 6-30 psi  
87/88 Actuators 3" - 6" Valves

750P Series Positioner  
Moore 750P Single or Double Acting Positioner  
Instrument Signals 3-15 psi and 6-30 psi  
Split Range  
87/88 Actuators 1" - 6" Valves  
84/85/86 Actuators 1" - 8" Valves

8012 Electropneumatic Valve Positioner  
(See Specification Data CS5000)  
Instrument Signals 10-50 mA, 104 ohms  
4-20 mA, 173 ohms  
87/88 Actuators 3" - 6" Valves

7000 Electropneumatic Transducer  
(See Instruction ES6700)  
Input Range 4-20 mA, 550 ohms  
Split range up to 3 times  
Output (Direct or Reverse)  
3-15 psi, adjustable to 0-20

496 Rotary Electric Switches  
496-1 (1-Switch SPDT)  
496-2 (2-Switches SPDT)  
496-3 Position Transmitter  
496-6 (1-Switch DPDT)  
496-7 (2-Switches DPDT)  
(See Specification Data CS7000)

2700 Controllers  
(See Specification Data CW6000)

80-4 or 80-40 Airset  
(See Specification Data CY7800)  
77-6 Lockup Valve  
(See Specification Data CY7700)  
77-8 Transfer Valve  
(See Specification Data CY8000)  
2" Gauge Various Ranges

Solenoid Valves  
ASCO, Versa, Westlock and Others

### Options

Environmental Capabilities (LE Packing)

Body Drain Plug

Other Materials

Other Flange Facings, Graylok

NACE Compliance

Custom Trim Materials

Nondestructive Examination

Volume Tank - Trip System

Electric and Electro-Hydraulic Actuators

Double Acting Cylinder Actuators  
154 sq. in., 314 sq. in., 200 sq. in., 400 sq. in., 1000 sq. in.

Snubber Mechanism for Cylinder Actuators

Extension Bonnets

Quick Response Unit

Hydraulic Manual Override (Cylinder Actuator)

Bailey AV 1/2/3/ Single and Double Acting Positioners  
for Cylinder or Domotor Operators

High Pressure / Low Temperature Rating

For additional Accessories and Options, consult the Masoneilan factory or your representative.

**Facilities:** Brazil, Canada, France, Germany, Italy, Japan, Mexico,  
Netherlands, Singapore, Spain, United Kingdom, United States



Masoneilan North American Operations  
Dresser Valve & Controls Division  
Dresser Industries, Inc.  
Marketing Services  
15112 Morales Road  
P.O. Box 60078 (77205-0078)  
Houston, Texas 77032  
(281) 971-6500 • Fax (281) 971-6569